

## ANALYSIS OF CONSANGUINEOUS AND NON-CONSANGUINEOUS PEDIGREES RELATED TO THE MODE OF TRANSMISSION OF ESSENTIAL HYPERTENSION – STUDY BASED ON SERENE THREONINE KINASE-39 GENE SINGLE NUCLEOTIDE POLYMORPHISM rs35929607 IN A POPULATION OF SINDH, PAKISTAN

Loung V Umedani

Department of Basic Medical Science, College of Medicine, King Saud Bin Abdul Aziz University for Health Science, Riyadh, KSA

Correspondence to: Loung V Umedani (umedani@gmail.com)

DOI: 10.5455/ijmsph.2014.290520143

Received Date: 04.05.2014

Accepted Date: 29.05.2014

### ABSTRACT

**Background:** The consanguineous marriages are very common worldwide with a risk of acquiring a recessive gene mainly in multi-generational tradition of first cousin marriages. In Pakistan, the Muslim majority has more prevalence of practicing consanguinity than the Hindus.

**Aims & Objective:** We studied the Serene Threonine Kinase-39 Single Nucleotide A > G Polymorphism rs35929607; and comparatively analyzed recessive versus dominant mode of transmission of essential hypertension by plotting genotypes on the pedigree maps of both indicated populations.

**Materials and Methods:** This was Cross sectional, case-controlled and pedigree based study. After getting an approval from the Aga Khan University Ethical Review Committee, we recruited N=130 members from 4 pedigrees (n=67 from 2 consanguineous pedigrees: 25 males and 42 females; and n=63 from 2 non-consanguineous pedigrees with 32 males and 31 females). We genotyped N=96 participants and calculated the prevalence of genotypes and frequencies of the allele A and G. Prevalence of AA, GG and AG genotypes were calculated. Assessment for concordance with HWE was performed. Chi-square and odds ratio with 95% confidence limitation for frequencies of allele A and allele G was calculated. Relation of EHTN transmission with the homozygosity and heterozygosity was plotted against the participants in the pedigree trees.

**Results:** Consanguineous pedigrees showed frequencies of 62.26% for AG, 35.85% for AA and 1.89% for GG genotypes; and frequency of reference allele (A) was 67.0% and of rare allele (G) 33.0% ( $\chi^2 = 8.80$  and p-value 0.003). Non-consanguineous pedigrees showed 53.49% for AG, 44.19% for AA and 2.33% for GG and frequency of reference allele (A) 71.0% and rare allele (G) was 29.0% ( $\chi^2 = 3.79$  and p-value 0.0514). The p-values indicate that both populations are not falling in concordance with Hardy Weinberg Equilibrium (HWE) and are stratified.

**Conclusion:** Consanguineous pedigrees in context to STK-39 SNP rs35929607, showed recessive pattern of inheritance as opposed to the non-consanguineous cohort showing dominant pattern of inheritance of essential hypertension. This outcome needs further confirmation by carrying out study at a broader scale by recruiting large sample size.

**Key Words:** Consanguinity; Essential Hypertension; Inheritance; Pedigree Analysis; Serene Threonine Kinase 39

### Introduction

Literally the word consanguinity means shared blood (i.e. Con: shared, Sanguis: blood). All marital relations which share the common biological ancestors are regarded as consanguineous. The marital relations are derived through multiple factors viz. social, cultural, literacy level, religious and economic. Some families practice consanguinity to retain the family ties and to maintain the property to be owned intrinsic to family.<sup>[1,2]</sup> It is estimated that one billion of the current global population live in communities with a preference for consanguineous marriage.<sup>[3,4]</sup> Consanguineous marriage is traditional and is well respected in most communities of North Africa, Middle East and West Asia, where intra-familial unions collectively account for more than 50% of all marriages.<sup>[5]</sup> Marriages among blood relatives are being practiced since time immemorial and in multiple religions. It was in practice among Middle East Muslims

and Subcontinent Hindus even before the emergence of Islam. The marital relation between the first cousins is the commonest variety in practice. Consanguinity is attributed to attract attention among medical and population geneticists, clinicians and social scientists.

People who are blood relatives share a greater proportion of their genes than unrelated people, and thus potentially have the same mutated recessive gene.<sup>[6]</sup> Risk will increase in societies where there is a multi-generational tradition of first cousin marriages, rendering couples closer in genetic relationship.<sup>[6]</sup>

Epidemiological studies show that the essential hypertension is a multifactorial disease with heritable and genetic factors also playing a role in its etiology.<sup>[7]</sup> The latter aspect is supported by cross-sectional studies that prove familial aggregation of the disorder despite different environmental factors playing role in its

occurrence.<sup>[8,9]</sup>

The Pakistani population consists of multiple ethnicities and sub-ethnicities. Each ethnicity has its own culture and set of traditions which include marry their children to first cousins. Minority communities are concentrated mostly in Sindh. Muslims form the majority and they are a more consanguineous group regardless of ethnicity. In Pakistan, the frequencies of consanguineous marriages have been noticed varying from 91.19 per cent in the Balochs of Balochistan as reported by Mian and Mushtaq in 1994 to 56.56 per cent in the cities of Punjab as observed by Shami in 1989 studies.<sup>[10]</sup> Pakistani communities living in Britain have also a high rate of 50-60 percent of consanguinity as indicated by Corry in 2002.<sup>[10]</sup>

Consanguinity rates vary among majority ethnicities as opposed to sub-ethnicities from minorities in Pakistan which are partly strictly non-consanguineous but some of them practice consanguinity. The effect of consanguinity shows up as variable disease prevalence and severity in different ethnic groups.

The world population manifests consanguineous and non-consanguineous marriage traditions in individuals even following the same religion. However, there are some sects where strict non-consanguineous marriages take place. This is again fortified by keeping the marital relations restricted to the geographical locations. For instance, the Sikhs of India arrange the marriages in families with absence of maternal and paternal blood relation. They do not arrange marriages in the same village or town as well. This is an example of non-consanguinity in its most pure form. In Hindus, multiple patterns occur, but certain sects who are in majority practice strict non-consanguinity. Consanguinity is therefore found in multiple Hindu communities e.g. South Indian Hindu Brahmans. The DNA finger prick samples were tested for pattern and levels of homozygosity, autozygosity and gametic disequilibrium in such populations.<sup>[11]</sup> Consanguinity had been reported with transmission of both beneficial traits and the unfavorable traits as well.

The majority of marital practices in India are based on religious and social relations. Consanguinity is found in Sikhs and Arian-Dravidians. In the latter, at least former seven paternal and five maternal generations should compulsorily reveal absence of marital relation for arranging any engagement; but some of their sub-

communities also practice consanguinity. The Hindu marriage act 1955 says that the marriage between two persons related with five generations on father's side and three generations on the mother's side is void unless permitted by local custom.<sup>[12]</sup> In entire India about 89,777 total ever-married women were studied. This analysis showed the percentage of close consanguineous marriages (among cousins, and among uncles and nieces) was 12%, remote consanguineous marriages (with brother in law and other relatives) 4.3% and 83.7% as non-consanguineous marriages.<sup>[12]</sup> The maximum close consanguineous region was South India 29.2% and minimum consanguineous as 1.7% in North India.<sup>[12]</sup>

The Muslims in general from a global perspective reveal strongest preference for occurrence of consanguinity but, it should be noted that in India, except Sikhs the consanguinity was found in all religious communities namely Hindus, Parsees, Christians and Muslims etc.<sup>[12,13]</sup> In Pakistan, Sindhi Muslim ethnicities are characterized by high prevalence of consanguineous marriages; versus Sindhi Hindu ethnicities which in majority practice strict non-consanguinity but some of them also practice consanguinity.

It had been observed in many studies that the consanguinity is associated with occurrence of congenital and genetic disorders.<sup>[14,15]</sup> It is estimated that the risk of developing essential hypertension is increased two- to four-fold if one or both parents are diagnosed to have this disorder.<sup>[16]</sup>

Increased arterial stiffness and increased BMI is observed in children with positive history of parental hypertension.<sup>[17]</sup> It is also known that the complex disorders like hypertension, type - II diabetes and atherosclerosis are known to have a polygenic basis.<sup>[18]</sup> These multi-gene effects are produced by contributions of several genes where none of them has strong penetrance (minor gene effect). In such cases, the genes or alleles that increase disease susceptibility vary among individuals and usually follow a recessive pattern of inheritance. Therefore, it is generally after long periods of interbreeding in a given population that such recessive traits become endemic. This, however, does not seem to be the case in non-consanguineous populations because there is little chance of recessive traits getting pooled. There appears to be a major gene effect at work in one population in causing hypertension indicating that there may be two to four candidate genes/alleles with strong

penetrance to cause high blood pressure in these individuals.

We studied single nucleotide polymorphism (SNP) of serine threonine kinase 39 rs35929607. STK39 covers 293.65 kilo base region i.e. from 168812426 to 168518776 on the reverse strand. This was published in a study performed in the Amish and non-Amish participants.<sup>[19]</sup> We performed the study on the same SNP in Pakistan on participants from consanguineous and non-consanguineous pedigrees to look at the pattern of inheritance and zygosity with respect to STK39 gene.

It is observed that single nucleotide polymorphisms (SNPs) occur on average once per 250–1000 bp. The studied SNP produces DNA sequence variants in the genome.<sup>[20,21]</sup> The STK39 is expressed in the distal nephron and influence the blood pressure by altering renal Na<sup>+</sup> excretion<sup>[19]</sup> It was found that rs35929607 is a conserved nucleotide within a highly conserved sequence element. Less common G allele is associated with higher BP which enhances transcription predicted to up-regulate expression of STK39 gene<sup>[19]</sup> The functional SNP rs35929607 provided a more significant association to raise blood pressure than the other studied SNPs genotyped in the indicated GWA study. So, SNP consistent with rs35929607 is regarded as being either a better surrogate for the functional variant or it is the functional variant by itself. In Amish study, the site of action of the STK39 was confirmed by immunolocalization in the thick ascending limb of the loop of Henle and distal convoluted tubules of the kidney. Presence of the G allele of rs35929607 would promote Na<sup>+</sup> reabsorption, thereby increasing intravascular volume and blood pressure.<sup>[19]</sup>

In the present study, we used tetra primer ARMS-PCR technique to detect the SNPs for this gene because it has many advantages for being rapid, simple, cost effective and accurate.<sup>[22]</sup> This technique is utilized in studying genetic determinants of complex diseases e.g. hypertension etc.<sup>[23]</sup> The data about the observed genotypes was plotted against the members in the consanguineous and non-consanguineous pedigree maps and studied for the pattern of transmission of essential hypertension.

## Materials and Methods

The study was undertaken after approval from the Ethics Review Committee (ERC) of the Aga Khan University

(AKU), Karachi. The consent form was approved by AKU-ERC and was administered to the participants. Signature of the participant or a thumb impression in case of illiterate participants was obtained after explaining the objectives of the research. In case of children, a parent or guardian's signature or thumb impression was also obtained. We carried out preliminary visits to the research area followed by trips to record the pedigree tree. We also recorded the information about presence of essential hypertension (EHTN) and comorbid (i.e. stroke, ischemic heart disease and development of diabetes mellitus after the onset of hypertension).

This was a case-controlled study carried out at Tharparker, Sindh, Pakistan (location: 24° 42' 0" North and 70° 11' 0" East coordinates) during 2011-2012. This area was selected for accurate matching of cases and controls from consanguinity perspectives. Tharparker area is well known to inhabit some of the Hindu communities which practice strict non-consanguinity from known historical past.

We selected 4 pedigrees viz. 2 with positive history of consanguinity and the 2 from purely non-consanguineous families for comparative assessment of mode of transmission of EHTN by carrying out genotyping for the STK39 single nucleotide polymorphism at rs35929607.

Total N=130 participants were selected (i.e. n=67 from two consanguineous pedigrees containing 25 males and 42 females; and n=63 from two non-consanguineous pedigrees with 32 males and 31 females). We recruited all the participants based on family tree by recording at least 4-generations in each pedigree. We genotyped N=96 participants (i.e. n=53 from consanguineous pedigrees and n=43 from non-consanguineous). From these participants we calculated the prevalence of genotypes and frequencies of the allele A and G.

Three blood pressure measurements were taken from the left arm at 15-minute intervals in the resting state from each individual. Any individual with systolic blood pressure >140mmHg and diastolic blood pressure >90mmHg on all the three occasions was labeled as hypertensive.

Blood samples were collected in tubes containing ethylenediamine tetra acetic acid (EDTA) and stored at 4°C immediately. DNA was extracted from whole blood by using phenol-chloroform-isoamyl alcohol method.<sup>[24]</sup>

FASTA sequence showing point mutation in STK39 gene at SNP rs35929607 was obtained from the National Center for Biotechnology Information (NCBI) website. Primers were designed for tetra primers amplification refracton mutation system-polymerase chain reaction (ARMS-PCR) method by using the software [http://cedar.genetics.soton.ac.uk/public\\_html/primer1](http://cedar.genetics.soton.ac.uk/public_html/primer1). (viz. inner forward CTC ATG GAA TTA AAG GAT TAT TAG GAT AAC G Mer31, Outer forward AAC ACT CTC ACA AGA AGA GAT CCC AGT G Mer28, Inner reverse CAC ATT TTG GCA GTG TTT GGA CAG CT Mer26, Outer reverse CTC CCA GGT CGT TTT CAA ACA AAA ATA A Mer28).

All participants were genotyped with 100% quality controls and we got accurate results. In order to detect allele A and allele G we used tetra primer ARMS-PCR reaction using an Eppendorf Gradient Thermocycler. The reaction mix was incubated and the following programme was used: 95°C for 7 minutes (initial denaturation); 95°C for 45 seconds (denaturation, 44 cycles); 66°C for 45 seconds (annealing, 44 cycles); 72°C for 45 seconds (extension, 44 cycles); 72°C for 7 minutes (Final extension) and 4°C (hold phase). The PCR products were separated by 2.5% agarose gel electrophoresis run at 120V for 30 to 40 minutes, and the gel was transferred to Gel Doc BioRad) for visualization under ultraviolet light. Bands for the required product sizes were obtained (i.e. outer primers 349bp, allele-A 175bp and allele-G 231bp).

**Data Analysis**

The data was analyzed statistically for prevalence of individual homozygous i.e. AA and GG genotypes, and heterozygous AG genotypes, frequencies of alleles A and G by using software <http://www.koonec.com/k-blog/2010/06/20/hardy-weinberg-equilibrium-calculator/>. Assessment for concordance with Hardy Weinberg Equilibrium (HWE) was performed. Chi-square and odds ratio with 95% confidence limitation for frequencies of allele A and allele G was calculated. Relation of EHTN transmission with the homozygosity and heterozygosity was plotted against the participants in the pedigree trees for interpretation using software Cyrillic version 2.1

**Results**

Genotype frequencies obtained for the consanguineous pedigrees in this study were found out to be 62.26% for

AG, 35.85% for AA and 1.89% for GG. Frequency of reference allele (A) was 67.0% and of rare allele (G) was 33.0% ( $\chi^2 = 8.80$  and p-value 0.003) indicating that the population is not falling in concordance with Hardy Weinberg Equilibrium (HWE) and is being stratified (Table 1). Genotype frequencies obtained for the non-consanguineous pedigrees were found out to be 53.49% for AG, 44.19% for AA and 2.33% for GG. Frequency of reference allele (A) was 71.0% and of rare allele (G) was 29.0% ( $\chi^2 = 3.79$  and p-value 0.0514) indicating that the population is not falling in concordance with Hardy Weinberg Equilibrium (HWE) and is being stratified (Table 1).

**Table-1: Displaying the genotype and allele frequencies in the consanguineous (n= 53) and non-consanguineous (n=43) pedigrees subjects**

Participants	AG	AA	GG	A-allele	G-allele	$\chi^2$	P-Value
<b>Consanguineous Pedigrees</b>							
53 (100%)	33 (62.26)	19 (35.85)	1 (1.89)	0.67	0.33	8.80	0.0030
<b>Non Consanguineous Pedigrees</b>							
43 (100%)	23 (53.49)	19 (44.19)	1 (2.33)	0.71	0.29	3.79	0.0514
<b>Total Population</b>							
96 (100%)	56 (58.33)	38 (39.58)	2 (2.08)	0.69	0.31	12.27	0.0005

Figures in the bracket show the percentage. The p-value 0.0005 showing that the studied population is not falling in concordance with Hardy Weinberg Equilibrium (HWE).

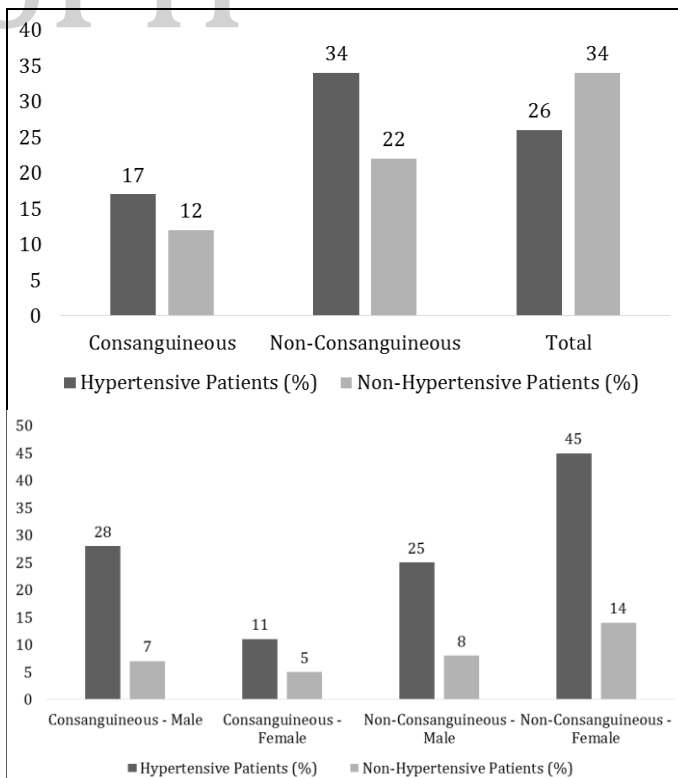

**Figure-1: The percentage of essential hypertension (EHTN) in consanguineous, non-consanguineous and total population; and the gender distribution in each cohort**

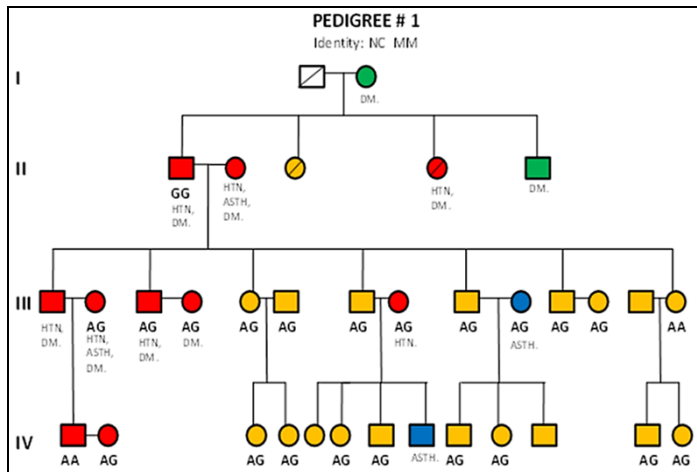

**Figure-2: Pedigree from a non-consanguineous family showing pattern of transmission of pathologic trait and inheritance.** (Pedigree displaying dominant pattern of inheritance: Supporting positive features found were transmission of EHTN trait to the offsprings, marriage of both affected parents gave affected children, predominant heterozygous genotype pattern (AG-genotype) and absence of positive history of consanguineous marriages. Trait for diabetes was found to follow the similar pattern of transmission. Pattern for transmission of asthma could not be commented due to scarcity of data.)

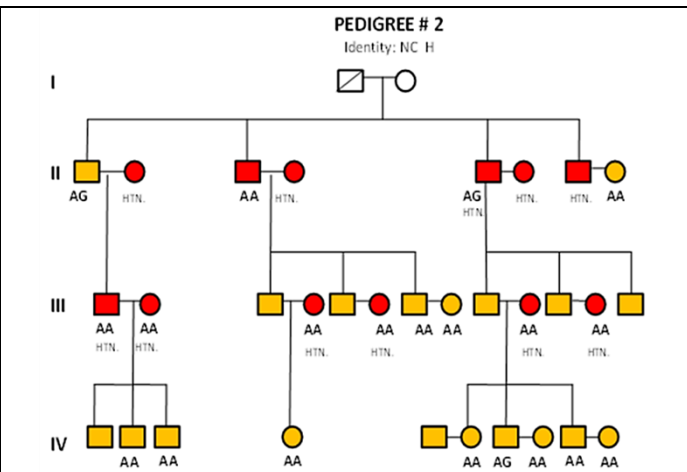

**Figure-3: Pedigree from non-consanguineous family showing pattern of transmission of pathologic trait and inheritance.** (Pedigree displaying dominant pattern of inheritance: There is transmission of EHTN trait to the offsprings. From genetic standpoint when both parents are affected the children may or may not be found affected as seen in this family. There was absence of positive history of consanguineous marriages in this pedigree.)

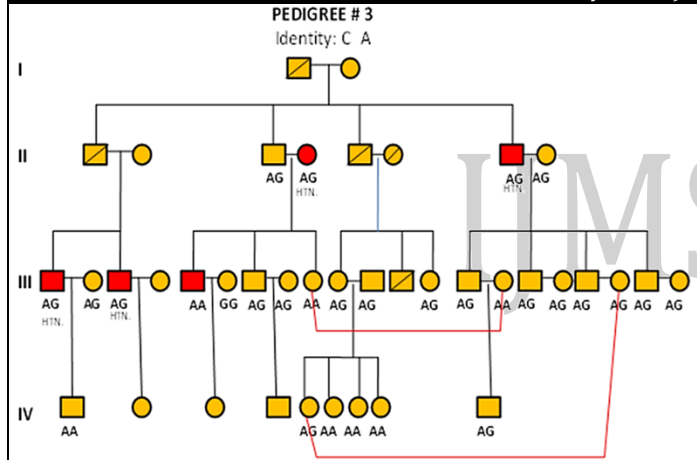

**Figure-4: Pedigree from a consanguineous family showing pattern of transmission of pathologic trait and inheritance.** (Pedigree showing recessive pattern of inheritance: Supporting positive features found were clinically normal phenotype pattern of both the parents (Refer the first couple in the second generation where disease is found to be transmitted to all the offsprings) and a positive history of consanguineous marriages in this pedigree.)

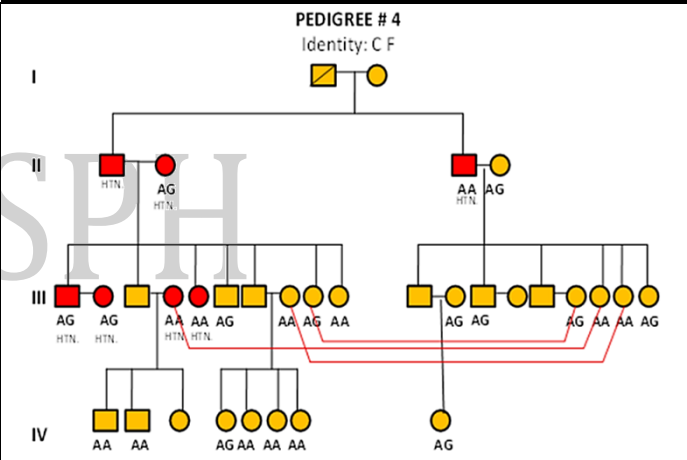

**Figure-5: Pedigree from a consanguineous family showing pattern of transmission of pathologic trait and inheritance.** (Pedigree displaying recessive pattern of inheritance: Supporting positive features found were absence of EHTN trait in both parents (Refer normal parents found in first generation giving all the offsprings found to be affected in second generation). There is positive history of consanguinity in this family.)

Genotype frequencies obtained for the total population (all four pedigrees) were found out to be 58.33% for AG, 39.58% for AA and 2.08% for GG. Frequency of reference allele (A) was 69.0% and of rare allele (G) was 31.0% ( $\chi^2 = 12.27$  and p-value 0.0005) indicating that the population is not falling in concordance with Hardy Weinberg Equilibrium (HWE) and is being stratified (Table 1).

Figure 1 shows that in entire population of N130 participants the incidence of EHTN was 26%. An increased percentage of essential hypertension i.e. 34% was noted in non-consanguineous participants as

compared to the consanguineous i.e. 17%. Among the non-consanguineous cohort the females displayed more incidence of EHTN i.e. 45% than the males i.e. 25%. On the contrary in the consanguineous group, more males i.e. 28% were observed to have EHTN than the females 11%.

Analysis of four pedigree maps from this population was done. Two pedigrees were studied from consanguineous and two from non-consanguineous families. All the family trees manifested some pattern of genealogical flow of pathognomic trait into subsequent offsprings described in each map respectively. Pedigrees reveal that

EHTN and other disorders have tendency to run through subsequent generations (Figures 2 thru 5). The results showed that the consanguineous pedigrees displayed a recessive pattern while the non-consanguineous pedigrees displayed dominant pattern of transmission of essential hypertension (Figures 2 thru 5).

## Discussion

Consanguinity is prevalent globally as shown in the world map (Figure 6).<sup>[25]</sup> Due to cultural reasons the consanguineous marriages are favored in Pakistan. Generally the first cousin marriage is the most common form of consanguinity elsewhere and in Pakistan also. Consanguinity owes both kinds of biological consequences i.e. if it is practiced in absence of inheritable diseases it can transmit beneficial phenotypic characters to the offsprings e.g. intellect, artistic skills, good health and attractive body features etc. Consanguinity does not increase the risk for autosomal dominant conditions in offspring when one of the parents is affected, nor for X-linked recessive conditions if neither parent is affected.<sup>[26]</sup> It becomes problematic and need to be counseled on scientific basis whenever there is a definite history of inheritable genetic disorders mainly those of autosomal recessive character.

Consanguinity has risk of increasing the frequency of

homozygotes and reducing the frequency of heterozygotes thereby increasing the chances of genetic transmission of diseases running in the offsprings. It is important that there should be screening programmes particularly to search the families with expected risk of transmission of genetic disorders so that they should be effectively counselled. It is also important that the primary health care providers, specifically those working in highly consanguineous communities, should have clear evidence-based guidelines in counselling a consanguineous couple to minimize their risks for having affected offspring. Due to the change in world presently known as a global home, the incidence of consanguinity is decreasing at some slower rate but it still prevails in many geographical areas due to cultural and religious reasons. The frequency of arranged marriages with consanguinity may be declining in recent years due to the increasing number of females reaching university level education which gives them a broader choice of marriage partner.<sup>[26]</sup> The other causes of declining rate of consanguinity could be high educational status, urbanization and industrialization; legal sanctions against child marriages; diminishing family size, health consciousness and awareness of harmful effects of inbreeding; increased mobility; better communication facilities and deviation from the traditional way of mate selection.<sup>[10]</sup>

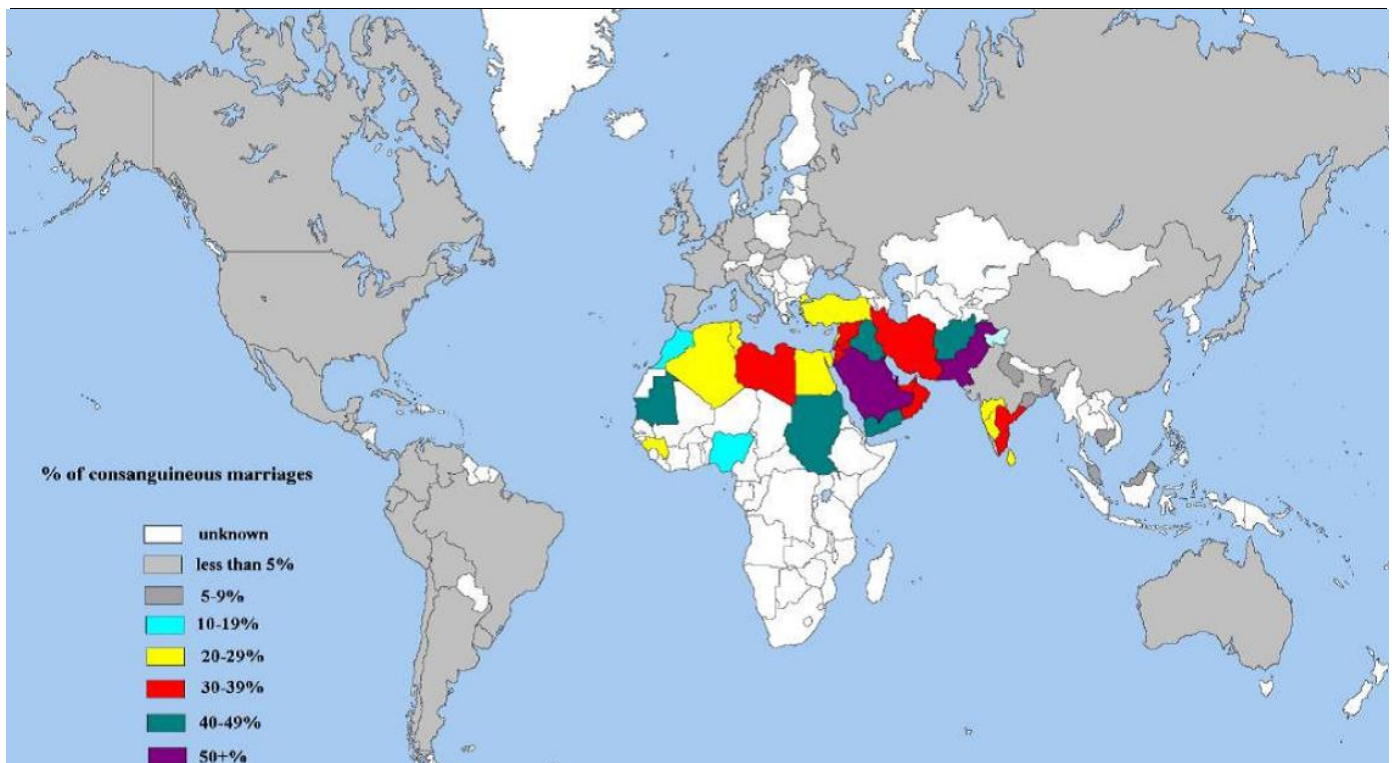

Figure-6: Global prevalence of consanguinity<sup>[25]</sup>

Autosomal recessive disorders occur in individuals who are homozygous for a particular recessive gene mutation. This means that they carry two copies (alleles) of the same gene.<sup>[27]</sup> Such carriers are not affected and will not display any signs that they are carriers, and so the subjects may be unaware that they carry the mutated gene. As relatives share a proportion of their genes, it is much more likely that the related parents will be carriers of an autosomal recessive gene and therefore their children are at a higher risk of an autosomal recessive disorder.<sup>[28]</sup> Pedigree-based estimates of consanguinity and the resultant levels of homozygosity have several limitations; in particular, they do not provide information on close-kin marriages that have occurred in distant generations ago and thus underestimate cumulative inbreeding effects, and with rare exceptions incorrectly ascribed paternity are not recorded.<sup>[29]</sup>

Recessive mode of transmission of diseases had been well understood and accepted kind of mechanism responsible for the monogenic disorders in context to consanguinity; but the complex disorders are less studied from consanguinity stand point.<sup>[30,31]</sup> This means that the most important reason for the spread of complex disorders is their mediation through multiple genes e.g. genes for obesity, BMI etc. and hence to regard these ones as multifactorial disorders. Therefore, the inheritance patterns for such disorders are also multifactorial respectively. It should be noted that the studies carried out so far show the controversial results about transmission of multifactorial disorders and consanguinity.<sup>[32-35]</sup> However, some diseases like the Alzheimer's disease show greater prevalence in some communities (i.e. 36%) probably due to polygenic disorders in this case being transmitted through undiscovered consanguineous recessive genes.<sup>[36,37]</sup>

Present accepted view about origin of essential hypertension (EHTN) is attributed to its multifactorial and polygenic nature. Etio-pathogenesis of EHTN encompasses combined effects of genetic factors (nature) and many environmental factors (nurture) to get elevated blood pressure.<sup>[38,39]</sup> Therefore, gene interactions will constitute the most important tools to clarify the feedback loops that operate to raise blood pressure. Such loops fall into hormonal, humoral or body fluid status, renal system, nervous system and other body organ system functions involved in regulation of blood pressure.

In this study the p-value of 0.0005 indicates that the

population is not falling in concordance with Hardy Weinberg Equilibrium (HWE) and is being stratified. This shows that it is not only the gene under study but it has multiple factors in the background leading to the genesis of essential hypertension in this study. It is also observed in the pedigree maps that EHTN has tendency to run through subsequent generations. On analysis based on criteria for the models of inheritance indicated in the (Figures 2 thru 5) it was found that the consanguineous pedigrees members matched the pattern of recessive model while the non-consanguineous displayed the dominant pattern. Although this falls clearly into and satisfies the generally accepted criteria of the mode of inheritance but the small sample size i.e. taking only four pedigrees as practiced in this study needs further confirmation of such findings. Hence there is a need to study this population at a larger scale by recruiting more number of subjects. The next appropriate study to be performed in this population would be collection of large number of samples at random from both the types of sub populations i.e. by recruiting consanguineous and non-consanguineous subjects. This should be followed by statistical analysis of the results using SPSS software formulae for the assessment of various types of models of inheritance i.e. recessive, dominant, co-dominant and over-dominant models.

## Conclusion

It is concluded that based on Serene Threonine Kinase 39 Single Nucleotide Polymorphism rs35929607, the consanguineous families showed recessive pattern of inheritance as compared to the non-consanguineous family subjects which showed dominant pattern of inheritance of essential hypertension. The outcome needs further confirmation by carrying out study at a broader scale by recruiting and analysing the study using large sample size.

## ACKNOWLEDGMENTS

Biological and Biomedical Sciences Department (BBSD) of the Aga Khan University (AKU), Karachi, Pakistan and Pakistan Medical and Research Council (PMRC) for providing funding to carry out this study.

## References

1. Hussain R, Bittles A. Sociodemographic correlates of consanguineous marriage in the Muslim population of India. *J Biosoc Sci* 2000;32:433-42.
2. Bittles AH, Mason WM, Greene J, Rao N. Reproductive behavior and health in consanguineous marriages. *Science* 1991;252:789-94.
3. Bittles AH, Black ML. Evolution in health and medicine Sackler

- colloquium: consanguinity, human evolution, and complex diseases. *Proc Natl Acad Sci USA* 2010;107:S1779–86.
4. Modell B, Darr A. Science and society: genetic counseling and customary consanguineous marriage. *Nat Rev Genet* 2002;3:225–9.
  5. Bittles A. The global prevalence of consanguinity. 2011. Available from: URL: <http://www.consang.net>
  6. Kristene BS. Genetics in Family Medicine. The Australian Handbook for General Practitioners. , Australia: Biotechnology. 2007.
  7. Gong M, and Hubner N. Molecular genetics of human hypertension. *Clin Sci (Lond)* 2006;110:315-26.
  8. Havlik RJ, Feinleib M. Epidemiology and genetics of hypertension. *Hypertension* 1982;4:III121-7.
  9. Zinner SH, Levy PS, Kass EH. Familial aggregation of blood pressure in childhood. *N Engl J Med* 1971;284:401-4.
  10. Bhasin MK, Shampa N. Consanguinity and Its Effects on Fertility, Mortality and Morbidity in the Indian Region: A Review. *Int J Hum Genet* 2012;12:197-301.
  11. Bittles AH. The bases of western attitudes to consanguineous marriage. *Dev Med Child Neurol* 2003;45:135-8.
  12. Banerjee SK, Roy TK. Parental Consanguinity and Offspring Mortality: The Search for Possible Linkage in the Indian Context. *Asia-Pacific Population Journal* 2002;17:17-38.
  13. Banerjee SK. Incidence of consanguineous marriage in India and its impact on child health and reproductive complications. Paper presented at: 19th Congress of the Indian Association for the Study of Population, 1996.
  14. Kushki AM, and Zeyghamy B. The effect of consanguineous marriages on congenital Malformation. *J Res Med Sci*, 2005. 10(5):298-301.
  15. Bromiker R, Baruch M. Association of parental consanguinity with congenital malformations among Arab newborns in Jerusalem. *Clin Genet* 2004;66:63-6.
  16. Hansen HS, Nielsen J R, Hyldebrandt N, Froberg K. Blood pressure and cardiac structure in children with a parental history of hypertension: the Odense Schoolchild Study. *J Hypertens* 1992;10:677-82.
  17. Meaney E, Samaniego V, Alva F, Valdovinos RA, Marrufo R, Vela A, et al. Increased arterial stiffness in children with a parental history of hypertension. *Pediatr Cardiol* 1999;20:203-5.
  18. Aghasadeghi K, Zarei-Nezhad M, Keshavarzi A, Mehrabani D. The prevalence of coronary risk factors in Iranian lor migrating tribe. *Arch Iran Med* 2008;11:322-5.
  19. Wang Y, O'Connell JR, McArdle PF, Wade JB, Dorff SE, Shah SJ, et al. From the Cover: Whole-genome association study identifies STK39 as a hypertension susceptibility gene. *Proc Natl Acad Sci USA* 2009;106:226-31.
  20. Collins FS, Brooks LD, Chakravarti A. A DNA polymorphism discovery resource for research on human genetic variation. *Genome Res*, 1998;8:1229-31.
  21. Kwok PY, Deng Q, Zakeri H, Taylor SL, Nickerson DA. Increasing the information content of STS-based genome maps: identifying polymorphisms in mapped STSs. *Genomics* 1996;31:123-6.
  22. Collins FS, Patrinos A, Jordan E, Chakravarti A, Gesteland R, Walters L. New goals for the U.S. Human Genome Project: 1998-2003. *Science* 1998;282:682-9.
  23. Ye S, Dhillon S, Ke X, Collins AR, Day I. An efficient procedure for genotyping single nucleotide polymorphisms. *Nucleic Acids Res* 2001;29:E88-8.
  24. Center for Cell and Gene Therapy. Phenol-chloroform-isoamyl alcohol method. Vector Development Lab Texas, USA. 2011. 1(Ref. 77030):vdl704.
  25. Hamamy H. Preconception consultation in primary health care settings. *J Community Genet* 2012;3:185–92.
  26. Hamamy H, Al-Hait S, Alwan A, Ajlouni K. Jordan communities and community genetics. *Community Genet* 2007;10:52–60.
  27. Marshall WJ, Bangert SK. Clinical biochemistry: metabolic and clinical aspects, 2nd ed. Edinburgh : Churchill Livingstone; 2008. p. 920.
  28. Benjamin PA. Genetics: A Conceptual Approach. In: FreemanWH. A Genetics Portal for Genetics, New York. 2012. p. 138.
  29. Bittles AH, Black ML. Consanguinity, human evolution and complex diseases. *PNAS* 2010;107:1779-86.
  30. Shami SA, Qaisar R, Bittles AH. Consanguinity and adult morbidity in Pakistan. *Lancet* 1991;338:954-5.
  31. Rudan I, Campbell H. Late-onset Inbreeding Effects. *Coll Antropol* 2004;28:943-50.
  32. Bittles AH. Empirical Estimates of Global Prevalence of Consanguineous Marriage in Contemporary Societies. *Morison Institute for Population and Resource Studies, Working Paper* 0074. Stanford: Stanford University. 1998. Available from: URL: [www.stanford.edu/group/morrinst/pdf/MorrisonPN0074.pdf](http://www.stanford.edu/group/morrinst/pdf/MorrisonPN0074.pdf)
  33. Bittles AH. Consanguinity and its relevance to clinical genetics. *Clin Genet* 2001;60:89-98.
  34. Jaber L, Shohat T, Rotter JI, Shohat M. Consanguinity and common adult diseases in Israeli Arab communities. *Am J Med Genet* 1997;70:346-48.
  35. Stoltenberg C, Magnus P, Lie RT, Daltveit AK, Irgens LM. Birth defects and parental consanguinity in Norway. *Am J Epidemiol* 1997;145:439-48.
  36. Farrer LA, Bovirrat A, Friedland RP, Waraska K, Korczyn AD, Baldwin CT. Identification of multiple loci for Alzheimer disease in a consanguineous Israeli-Arab Community. *Hum Mol Genet* 2003;12:415-22.
  37. Bowirrat A, Cui J, Waraska K, Friedland RP, Oscar-Berman M, Farrer LA, et al. Association between angiotensin-converting enzyme (ACE) and Alzheimer's disease (AD) among an elderly Arab population in Wadi Ara, Israel. *J Neuropsychiatr Dis Treat* 2005;1:73-6.
  38. Pickering G. Hypertension in general practice. *J R Soc Med* 1978;71:885-9.
  39. Barlassina C, Lanzani, C, Manunta P, Bianchi G. Genetics of essential hypertension: from families to genes. *J Am Soc Nephrol*, 2002;13:S155-64.

**Cite this article as:** Umedani LV. Analysis of consanguineous and non-consanguineous pedigrees related to the mode of transmission of essential hypertension – Study based on serine threonine kinase-39 gene single nucleotide polymorphism rs35929607 in a population of Sindh, Pakistan. *Int J Med Sci Public Health* 2014;3:955-962.

**Source of Support:** Biological and Biomedical Sciences Department (BBSD) of the Aga Khan University (AKU), Karachi, Pakistan and Pakistan Medical and Research Council (PMRC)

**Conflict of interest:** None declared